

## Free-standing cable distribution box KVS size 00-2

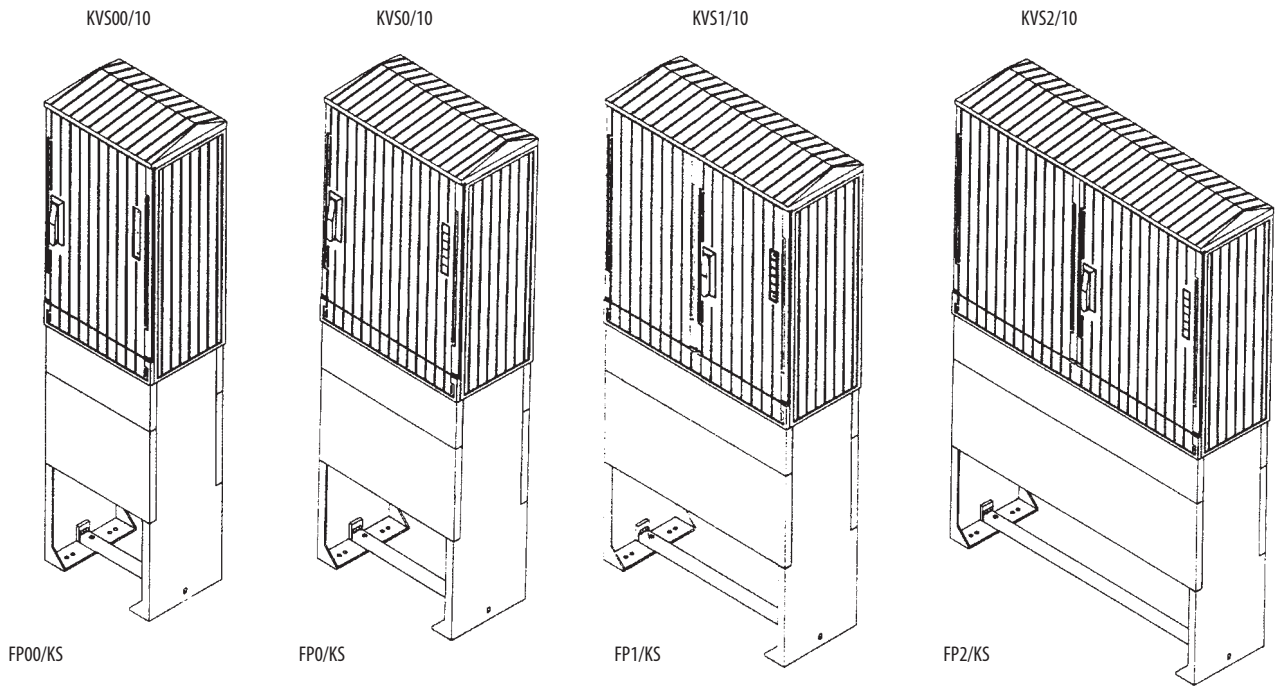

Fuse supports with fuse cartridges can be built into the cabinets. The following number of fuse supports size 1, 2, 3 can be built-in:

- KVS00/10      4 fuse supports
- KVS0/10      5 fuse supports
- KVS1/10      7 fuse supports
- KVS2/10      10 fuse supports

Fuse supports size 00 can also be built-in.

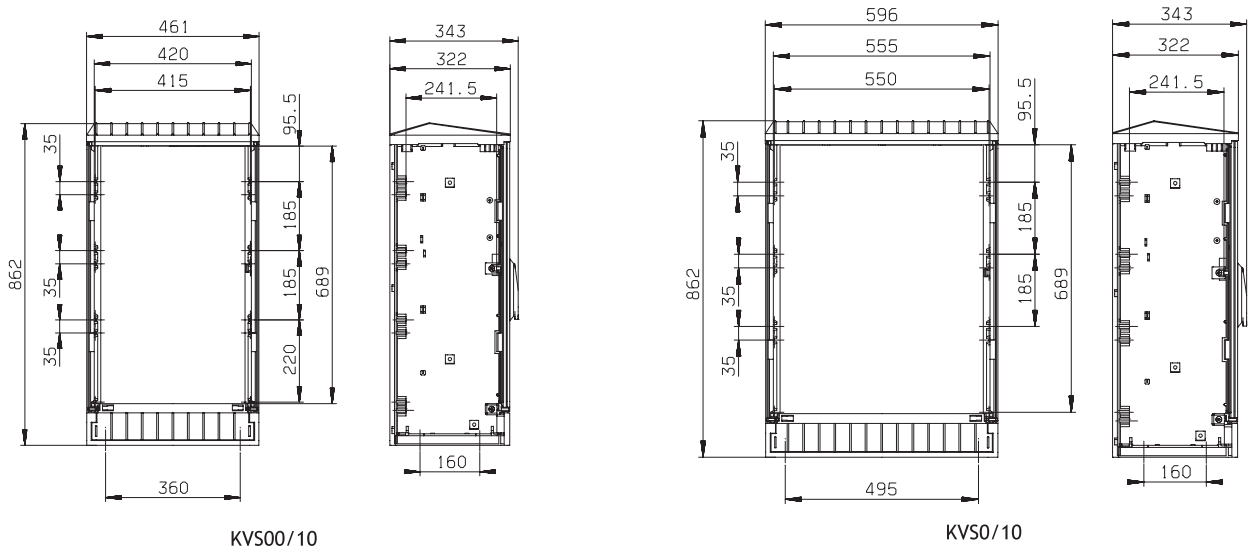

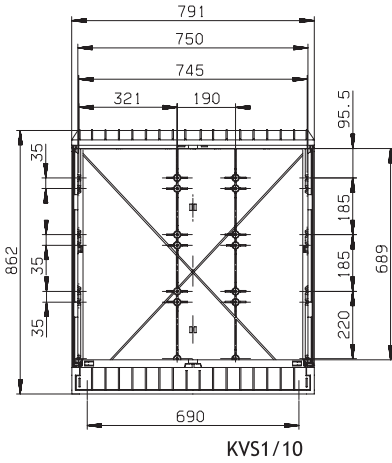

KVS1/10

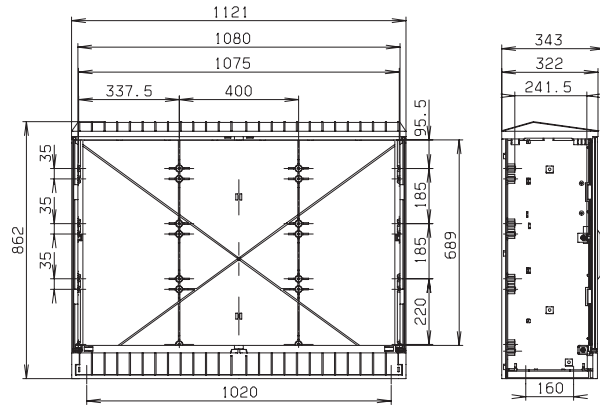

KVS2/10

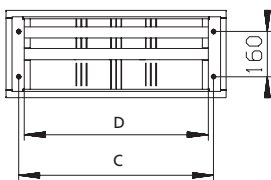
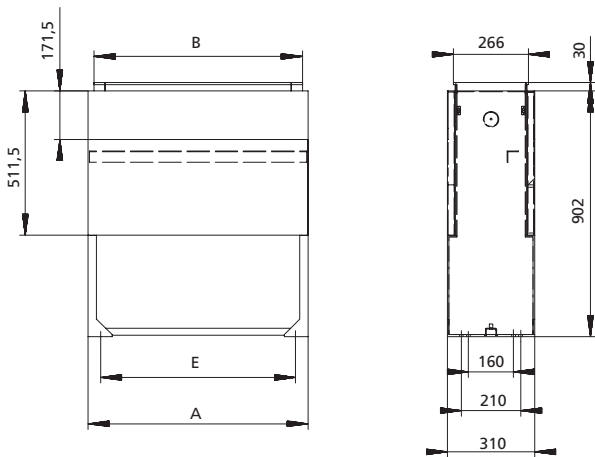

**Dimensions for polyester pedestals**

type	A	B	C	D	E
FP00/KS for KVS 00/10	450	408	360	322	360
FP0/KS for KVS 0/10	585	543	495	457	495
FP1/KS for KVS 1/10	780	738	690	652	690
FP2/KS for KVS 2/10	1110	1068	1020	982	1020

Proper mounting of KVS distribution boxes  
(to avoid condensation)

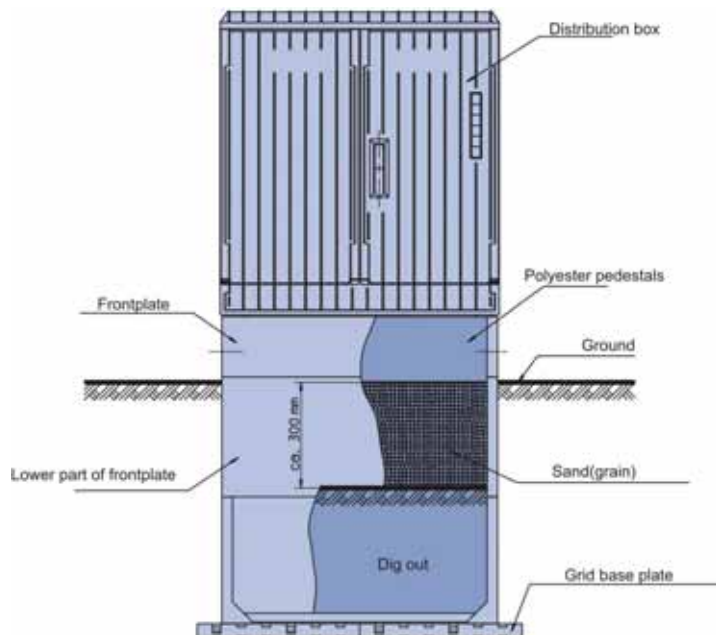

**Codensation in distribution boxes**

Due to the outdoor atmospheric conditions, condensed water develops in cable and distribution cabinets and precipitates at the inner surfaces. The humidity may lead to the corrosion of the metal parts and to the formation of creepage currents.